



P100

TECHNICAL DATA

Max crimping dia (mm/inch) ¹⁾	124/4.88
Max crimping dia with master dies (mm/inch)	150/5.9
Max crimping force (KN)	2800
Max crimping force (tonnage)	280
Cycle time 10 mm ²⁾	6.1
Hydraulic hose size (inch)	4"8
Industrial hose size (inch)	4.88 *
Die set series	32/140
Max opening (mm) ³⁾	+50
Max opening without dies (mm)	180
Master die D/L (mm)	140/120
Master die D/L (inch)	5.52-4.73
Motor Power (KW/HP) ³⁾	4.0/5.5 1.5/2.0 (400V 3 Phase)
Oil tank volume	80 L

DIMENSIONS (LxWxH)

Machine (mm)	800x650x900
Machine (inch)	31.5x25.6x35.4
Packaged (mm)	1000x1000x1000
Packaged (inch)	39.4x39.4x39.4

WEIGHT

Machine (kg/lbs)	450/992
Packaged (kg/lbs)	500/1102

* ACCORDING TO THE FITTING.

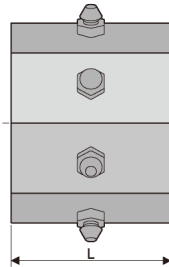
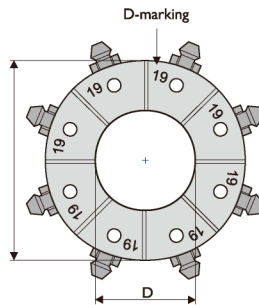

- 1) With standard dies. Crimping range can be increased with special dies.
- 2) Theoretical with 10 mm cycle.
- 3) Maximum opening is the total die travel. Add this value to the minimum crimping diameter of the die set used. The result is the maximum opening of the machine with die set in place.

FEATURES

Up to 4" 8SP Hose
Super High Pressure Hose Crimping (5000 Bar)
Production Purpose
Semi-Automatic Crimping Machine

OPTIONS

110V/220V 1 Phase
230V/440V/480V 3 Phase

CONTROL

Micro Dail(Digital Control)

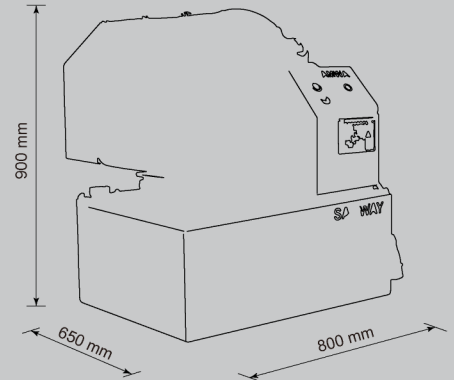

DIE SET 140-SERIES

DieSetNo	D (mm)	L (mm)	Crimp. range(mm)
18860/84	84	120	84.0-92.0
18860/92	92	120	92.0-100.0
18860/100	100	120	100.0-108.0
18860/108	108	120	108.0-116.0
18860/116	116	120	116.0-124.0

DIE SET 32-SERIES

DieSetNo	D (mm)	L (mm)	Crimp. range (mm)
*18506/10	10	55	10.0-13.0
*18506/13	13	55	13.0-16.0
18506/16	16	55	16.0-19.0
18506/19	19	55	19.0-22.0
18506/22	22	55	22.0-26.0
18506/26	26	55	26.0-30.0
18506/30	30	75	30.0-39.0
18506/39	39	75	39.0-45.0
18506/45	45	90	45.0-52.0
18506/52	52	90	52.0-57.0
18506/57	57	90	57.0-64.0
18506/64	64	90	64.0-69.0
18506/69	69	90	69.0-74.0
18506/74	74	100	74.0-78.0
18506/78	78	100	78.0-82.0

* Optional die sets at additional cost

Products images & Specifications may alter prior official notice at any time.